

S7T1636U4M

S7T1618U4M

S7T1609U4M 512Kx36 & 1Mx18 & 2Mx9 Quadruple-II+ BL4 SRAM w/ ODT

18Mb Quadruple-II+ BL4 w/ ODT SRAM Specification (2.5 Clock Read Latency)

165FBGA with Pb & Pb Free
(ROHS Compliant)

NETSOL RESERVES THE RIGHT TO CHANGE PRODUCTS, INFORMATION AND SPECIFICATIONS WITHOUT NOTICE.

Products and specifications discussed herein are for reference purposes only. All information discussed herein is provided on an "AS IS" basis, without warranties of any kind.

This document and all information discussed herein remain the sole and exclusive property of NETSOL. No license of any patent, copyright, mask work, trademark or any other intellectual property right is granted by one party to the other party under this document, by implication, estoppel or otherwise.

For updates or additional information about Netsol products, please contact to netsol@netsol.co.kr

S7T1636U4M
S7T1618U4M
S7T1609U4M 512Kx36 & 1Mx18 & 2Mx9 Quadruple-II+ BL4 SRAM w/ ODT

Document Title

**512Kx36 & 1Mx18 & 2Mx9 - Bit Quadruple-II+ Burst Length of 4 SRAM w/ ODT
(2.5 Clock Read Latency)**

Revision History

| Rev. No. | History | Draft Date | Remark |
|----------|--------------------|------------|-------------|
| 0.0 | Initial Draft | Oct. 2012 | Preliminary |
| 1.0 | Final spec release | Jun. 2014 | Final |

S7T1636U4M

S7T1618U4M

S7T1609U4M 512Kx36 & 1Mx18 & 2Mx9 Quadruple-II+ BL4 SRAM w/ ODT

512Kx36 & 1Mx18 & 2Mx9 - Bit Quadruple-II+ Burst Length of 4 SRAM w/ ODT (2.5 Clock Read Latency)

Features

- 1.8V+0.1V/-0.1V Power Supply.
- DLL circuitry for wide output data valid window and future frequency scaling.
- I/O Supply Voltage 1.5V+0.1V/-0.1V for 1.5V I/O, 1.8V+0.1V/-0.1V for 1.8V I/O
- Separate independent read and write data ports with concurrent read and write operation
- HSTL I/O
- Full data coherency, providing most current data .
- Synchronous pipeline read with self timed late write.
- Read latency: 2.5 clock cycles
- Registered address, control and data input/output.
- DDR(Double Data Rate) Interface on read and write ports.
- Fixed 4-bit burst for both read and write operation.
- Clock-stop supports to reduce current.
- Two input clocks(K and \bar{K}) for accurate DDR timing at clock rising edges only.
- Two echo clocks (CQ and \bar{CQ}) to enhance output data traceability.
- Data Valid pin(QVLD) supported
- On die termination (ODT) supported for data input, K, \bar{K} and \bar{BW}_x .
- Single address bus.
- Byte write (x9, x18, x36) function.
- Separate read/write control pin(\bar{R} and \bar{W})
- Simple depth expansion with no data contention.
- Programmable output impedance(ZQ).
- JTAG 1149.1 compatible test access port.
- 165FBGA(11x15 ball array) with body size of 13mmx15mm.

Key Parameters

| Part Number | Org. | Freq. (MHz) | Cycle Time (ns) | Access Time (ns) | RoHS |
|-----------------------|------|-------------|-----------------|------------------|------|
| S7T1636U4M-E(F)C(I)55 | x36 | 550 | 1.81 | 0.45 | O |
| S7T1636U4M-E(F)C(I)50 | | 500 | 2.0 | 0.45 | O |
| S7T1636U4M-E(F)C(I)45 | | 450 | 2.2 | 0.45 | O |
| S7T1636U4M-E(F)C(I)40 | | 400 | 2.5 | 0.45 | O |
| S7T1618U4M-E(F)C(I)55 | x18 | 550 | 1.81 | 0.45 | O |
| S7T1618U4M-E(F)C(I)50 | | 500 | 2.0 | 0.45 | O |
| S7T1618U4M-E(F)C(I)45 | | 450 | 2.2 | 0.45 | O |
| S7T1618U4M-E(F)C(I)40 | | 400 | 2.5 | 0.45 | O |
| S7T1609U4M-E(F)C(I)55 | x9 | 550 | 1.81 | 0.45 | O |
| S7T1609U4M-E(F)C(I)50 | | 500 | 2.0 | 0.45 | O |
| S7T1609U4M-E(F)C(I)45 | | 450 | 2.2 | 0.45 | O |
| S7T1609U4M-E(F)C(I)40 | | 400 | 2.5 | 0.45 | O |

* -E(F)C(I)

E(F) [Package type]: E-Pb Free, F-Pb

C(I) [Operating Temperature]: C-Commercial, I-Industrial

GENERAL DESCRIPTION

The S7T1636U4M, S7T1618U4M and S7T1609U4M are 18,874,368-bits Quadruple Synchronous Pipelined Burst SRAMs. They are organized as 524,288 words by 36bits for S7T1636U4M, 1,048,576 words by 18bits for S7T1618U4M and 2,097,152 words by 9bits for S7T1609U4M.

The Quadruple operation is possible by supporting DDR read and write operations through separate data output and input ports with the same cycle. Memory bandwidth is maximized as data can be transferred into and out of SRAM on every rising edge of K and \bar{K} . And totally independent read and write ports eliminate the need for high speed bus turn around. Address, data inputs and outputs, and all control signals are synchronized to the input clock (K or \bar{K}). Read data are referenced to echo clock (CQ or \bar{CQ}) outputs.

The S7T1636U4M, S7T1618U4M and S7T1609U4M support On Die Termination (ODT) for data input, input clock (K, \bar{K}) and \bar{BW}_x . On Die Termination can reduce the number of resistor elements and complex wiring on the system board. Accordingly, the system design can be simpler and cost effective.

Common address bus is used to access address both for read and write operations. The internal burst counter is fixed to 4-bit sequential for both read and write operations, requiring two full clock bus cycles. Any request that attempts to interrupt a burst operation in progress is ignored. Synchronous pipeline read and late write enable high speed operations. Simple depth expansion is accomplished by using \bar{R} and \bar{W} for port selection. Byte write operation is supported with \bar{BW}_0 and \bar{BW}_1 (\bar{BW}_2 and \bar{BW}_3) pins for x18 (x36) device and only \bar{BW} pin for x9 device.

IEEE 1149.1 serial boundary scan (JTAG) simplifies monitoring package pads attachment status with system.

The S7T1636U4M, S7T1618U4M and S7T1609U4M are implemented with Netsol's high performance 6T CMOS technology and is available in 165pin FBGA packages. Multiple power and ground pins minimize ground bounce.

S7T1636U4M

S7T1618U4M

S7T1609U4M 512Kx36 & 1Mx18 & 2Mx9 Quadruple-II+ BL4 SRAM w/ ODT

Logic Block Diagram - S7T1636U4M (512K x 36)

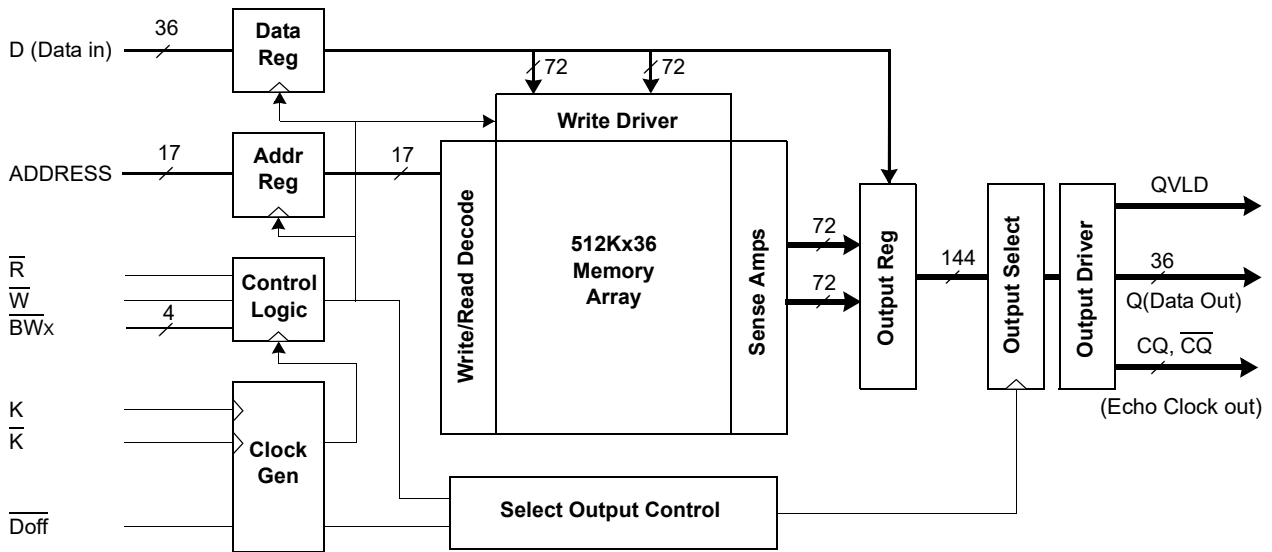

Logic Block Diagram - S7T1618U4M (1M x 18)

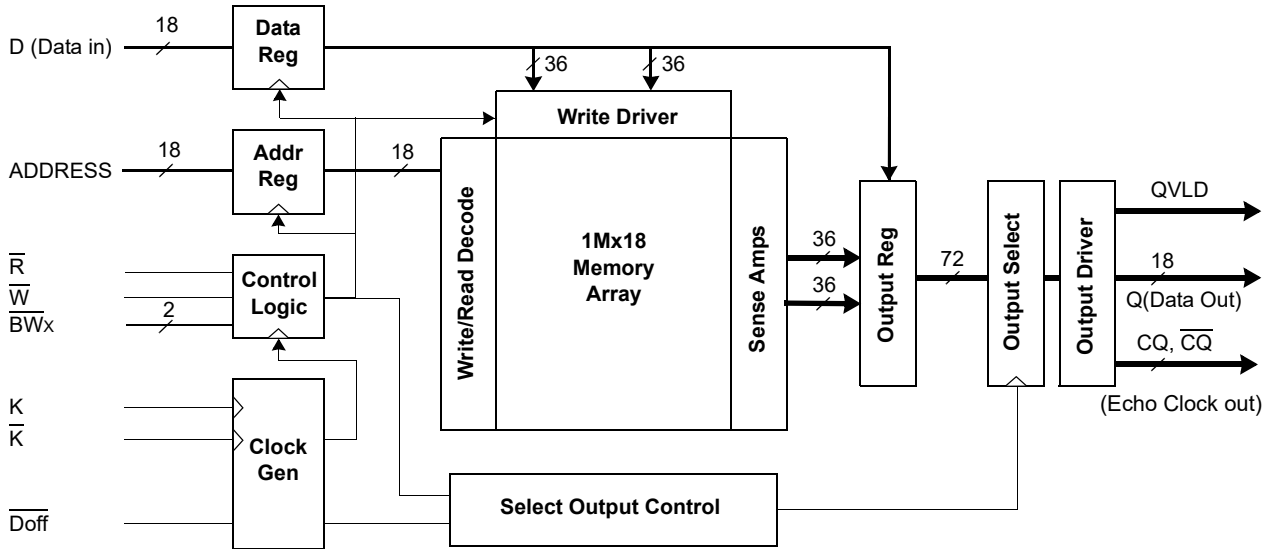

S7T1636U4M

S7T1618U4M

S7T1609U4M 512Kx36 & 1Mx18 & 2Mx9 Quadruple-II+ BL4 SRAM w/ ODT

Logic Block Diagram - S7T1609U4M (2M x 9)

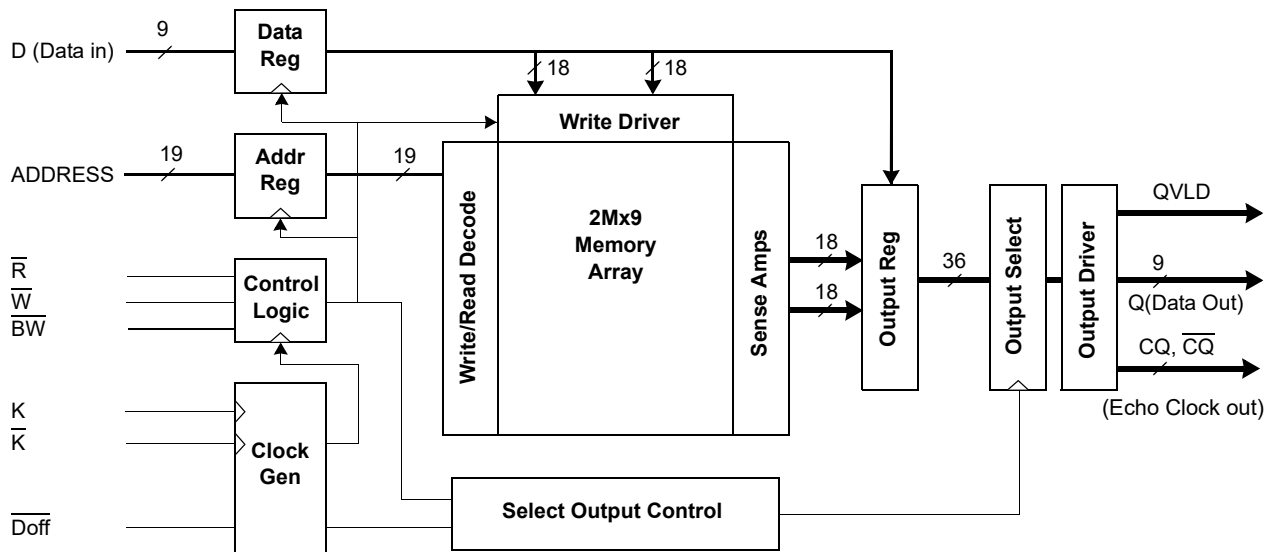

S7T1636U4M
S7T1618U4M
S7T1609U4M 512Kx36 & 1Mx18 & 2Mx9 Quadruple-II+ BL4 SRAM w/ ODT

165FBGA PKG Pin Configurations - S7T1636U4M (512Kx36) - Top View

| | 1 | 2 | 3 | 4 | 5 | 6 | 7 | 8 | 9 | 10 | 11 |
|----------|--------------------------|--------|--------|-----------------------|--------------------------|-----------------------|--------------------------|-----------------------|--------|--------|-----|
| A | $\overline{\text{CQ}}$ | NC/SA* | NC/SA* | $\overline{\text{W}}$ | $\overline{\text{BW}}_2$ | $\overline{\text{K}}$ | $\overline{\text{BW}}_1$ | $\overline{\text{R}}$ | NC/SA* | NC/SA* | CQ |
| B | Q27 | Q18 | D18 | SA | $\overline{\text{BW}}_3$ | K | $\overline{\text{BW}}_0$ | SA | D17 | Q17 | Q8 |
| C | D27 | Q28 | D19 | Vss | SA | NC | SA | Vss | D16 | Q7 | D8 |
| D | D28 | D20 | Q19 | Vss | Vss | Vss | Vss | Vss | Q16 | D15 | D7 |
| E | Q29 | D29 | Q20 | VDDQ | Vss | Vss | Vss | VDDQ | Q15 | D6 | Q6 |
| F | Q30 | Q21 | D21 | VDDQ | VDD | Vss | VDD | VDDQ | D14 | Q14 | Q5 |
| G | D30 | D22 | Q22 | VDDQ | VDD | Vss | VDD | VDDQ | Q13 | D13 | D5 |
| H | $\overline{\text{Doff}}$ | VREF | VDDQ | VDDQ | VDD | Vss | VDD | VDDQ | VDDQ | VREF | ZQ |
| J | D31 | Q31 | D23 | VDDQ | VDD | Vss | VDD | VDDQ | D12 | Q4 | D4 |
| K | Q32 | D32 | Q23 | VDDQ | VDD | Vss | VDD | VDDQ | Q12 | D3 | Q3 |
| L | Q33 | Q24 | D24 | VDDQ | Vss | Vss | Vss | VDDQ | D11 | Q11 | Q2 |
| M | D33 | Q34 | D25 | Vss | Vss | Vss | Vss | Vss | D10 | Q1 | D2 |
| N | D34 | D26 | Q25 | Vss | SA | SA | SA | Vss | Q10 | D9 | D1 |
| P | Q35 | D35 | Q26 | SA | SA | QVLD | SA | SA | Q9 | D0 | Q0 |
| R | TDO | TCK | SA | SA | SA | ODT | SA | SA | SA | TMS | TDI |

Notes: 1. * Checked No Connect (NC) or Vss pins are reserved for higher density address, i.e. 9A for 36Mb, 3A for 72Mb, 10A for 144Mb.
2. $\overline{\text{BW}}_0$ controls write to D0:D8, $\overline{\text{BW}}_1$ controls write to D9:D17, $\overline{\text{BW}}_2$ controls write to D18:D26 and $\overline{\text{BW}}_3$ controls write to D27:D35.

Pin Name

| Symbol | Pin Numbers | Description | Note |
|--|---|--|------|
| K, $\overline{\text{K}}$ | 6B, 6A | Input Clock | 1 |
| QVLD | 6P | Q Valid Output | |
| ODT | 6R | On die termination input | |
| CQ, $\overline{\text{CQ}}$ | 11A, 1A | Output Echo Clock | |
| $\overline{\text{Doff}}$ | 1H | DLL Disable when low | |
| SA | 4B,8B,5C,7C,5N-7N,4P,5P,7P,8P,3R-5R,7R-9R | Address Inputs | |
| D0-35 | 10P,11N,11M,10K,11J,11G,10E,11D,11C,10N,9M,9L 9J,10G,9F,10D,9C,9B,3B,3C,2D,3F,2G,3J,3L,3M,2N 1C,1D,2E,1G,1J,2K,1M,1N,2P | Data Inputs | |
| Q0-35 | 11P,10M,11L,11K,10J,11F,11E,10C,11B,9P,9N,10L 9K,9G,10F,9E,9D,10B,2B,3D,3E,2F,3G,3K,2L,3N 3P,1B,2C,1E,1F,2J,1K,1L,2M,1P | Data Outputs | |
| $\overline{\text{W}}$ | 4A | Write Control Pin, active when low | |
| $\overline{\text{R}}$ | 8A | Read Control Pin, active when low | |
| $\overline{\text{BW}}_0, \overline{\text{BW}}_1, \overline{\text{BW}}_2, \overline{\text{BW}}_3$ | 7B,7A,5A,5B | Block Write Control Pin, active when low | |
| VREF | 2H,10H | Input Reference Voltage | |
| ZQ | 11H | Output Driver Impedance Control Input | 2 |
| VDD | 5F,7F,5G,7G,5H,7H,5J,7J,5K,7K | Power Supply (1.8 V) | |
| VDDQ | 4E,8E,4F,8F,4G,8G,3H,4H,8H,9H,4J,8J,4K,8K,4L,8L | Output Power Supply (1.5V or 1.8V) | |
| Vss | 4C,8C,4D-8D,5E-7E,6F,6G,6H,6J,6K,5L-7L,4M,8M,4N,8N | Ground | |
| TMS | 10R | JTAG Test Mode Select | |
| TDI | 11R | JTAG Test Data Input | |
| TCK | 2R | JTAG Test Clock | |
| TDO | 1R | JTAG Test Data Output | |
| NC | 2A,3A,9A,10A,6C | No Connect | 3 |

Notes: 1. K or $\overline{\text{K}}$ cannot be set to VREF voltage.
2. When ZQ pin is directly connected to VDD output impedance is set to minimum value and it cannot be connected to ground or left unconnected.
3. Not connected to chip pad internally.

S7T1636U4M
S7T1618U4M
S7T1609U4M 512Kx36 & 1Mx18 & 2Mx9 Quadruple-II+ BL4 SRAM w/ ODT

165FBGA PKG Pin Configurations - S7T1618U4M (1Mx18) - Top View

| | 1 | 2 | 3 | 4 | 5 | 6 | 7 | 8 | 9 | 10 | 11 |
|----------|-------------------|------------------|------------------|------------------|-------------------|-----------------|-------------------|------------------|------------------|------------------|-----|
| A | \overline{CQ} | NC/SA* | NC/SA* | \overline{W} | \overline{BW}_1 | \overline{K} | NC | \overline{R} | SA | NC/SA* | CQ |
| B | NC | Q9 | D9 | SA | NC | K | \overline{BW}_0 | SA | NC | NC | Q8 |
| C | NC | NC | D10 | V _{SS} | SA | NC | SA | V _{SS} | NC | Q7 | D8 |
| D | NC | D11 | Q10 | V _{SS} | V _{SS} | V _{SS} | V _{SS} | V _{SS} | NC | NC | D7 |
| E | NC | NC | Q11 | V _{DDQ} | V _{SS} | V _{SS} | V _{SS} | V _{DDQ} | NC | D6 | Q6 |
| F | NC | Q12 | D12 | V _{DDQ} | V _{DD} | V _{SS} | V _{DD} | V _{DDQ} | NC | NC | Q5 |
| G | NC | D13 | Q13 | V _{DDQ} | V _{DD} | V _{SS} | V _{DD} | V _{DDQ} | NC | NC | D5 |
| H | \overline{Doff} | V _{REF} | V _{DDQ} | V _{DDQ} | V _{DD} | V _{SS} | V _{DD} | V _{DDQ} | V _{DDQ} | V _{REF} | ZQ |
| J | NC | NC | D14 | V _{DDQ} | V _{DD} | V _{SS} | V _{DD} | V _{DDQ} | NC | Q4 | D4 |
| K | NC | NC | Q14 | V _{DDQ} | V _{DD} | V _{SS} | V _{DD} | V _{DDQ} | NC | D3 | Q3 |
| L | NC | Q15 | D15 | V _{DDQ} | V _{SS} | V _{SS} | V _{SS} | V _{DDQ} | NC | NC | Q2 |
| M | NC | NC | D16 | V _{SS} | V _{SS} | V _{SS} | V _{SS} | V _{SS} | NC | Q1 | D2 |
| N | NC | D17 | Q16 | V _{SS} | SA | SA | SA | V _{SS} | NC | NC | D1 |
| P | NC | NC | Q17 | SA | SA | QVLD | SA | SA | NC | D0 | Q0 |
| R | TDO | TCK | SA | SA | SA | ODT | SA | SA | SA | TMS | TDI |

Notes: 1. * Checked No Connect(NC) pins are reserved for higher density address, i.e. 3A for 36Mb, 10A for 72Mb, 2A for 144Mb.
2. \overline{BW}_0 controls write to D0:D8 and \overline{BW}_1 controls write to D9:D17.

Pin Name

| Symbol | Pin Numbers | Description | Note |
|---------------------------------------|--|--|------|
| K, \overline{K} | 6B, 6A | Input Clock | 1 |
| QVLD | 6P | Q Valid Output | |
| ODT | 6R | On die termination input | |
| CQ, \overline{CQ} | 11A, 1A | Output Echo Clock | |
| \overline{Doff} | 1H | DLL Disable when low | |
| SA | 9A,4B,8B,5C,7C,5N-7N,4P,5P,7P,8P,3R-5R,7R-9R | Address Inputs | |
| D0-17 | 10P,11N,11M,10K,11J,11G,10E,11D,11C,3B,3C,2D,3F,2G,3J,3L,3M,2N | Data Inputs | |
| Q0-17 | 11P,10M,11L,11K,10J,11F,11E,10C,11B,2B,3D,3E,2F,3G,3K,2L,3N,3P | Data Outputs | |
| \overline{W} | 4A | Write Control Pin, active when low | |
| \overline{R} | 8A | Read Control Pin, active when low | |
| \overline{BW}_0 , \overline{BW}_1 | 7B, 5A | Block Write Control Pin, active when low | |
| V _{REF} | 2H, 10H | Input Reference Voltage | |
| ZQ | 11H | Output Driver Impedance Control Input | 2 |
| V _{DD} | 5F,7F,5G,7G,5H,7H,5J,7J,5K,7K | Power Supply (1.8 V) | |
| V _{DDQ} | 4E,8E,4F,8F,4G,8G,3H,4H,8H,9H,4J,8J,4K,8K,4L,8L | Output Power Supply (1.5V or 1.8V) | |
| V _{SS} | 4C,8C,4D-8D,5E-7E,6F,6G,6H,6J,6K,5L-7L,4M-8M,4N,8N | Ground | |
| TMS | 10R | JTAG Test Mode Select | |
| TDI | 11R | JTAG Test Data Input | |
| TCK | 2R | JTAG Test Clock | |
| TDO | 1R | JTAG Test Data Output | |
| NC | 2A,3A,7A,10A,1B,5B,9B,10B,1C,2C,6C,9C,1D,9D,10D,1E,2E,9E,1F,9F,10F,1G,9G,10G,1J,2J,9J,1K,2K,9J,1L,9L,10L,1M,2M,9M,1N,9N,10N,1P,2P,9P | No Connect | 3 |

Notes: 1. K or \overline{K} cannot be set to V_{REF} voltage.
2. When ZQ pin is directly connected to V_{DD} output impedance is set to minimum value and it cannot be connected to ground or left unconnected.
3. Not connected to chip pad internally.



S7T1636U4M**S7T1618U4M****S7T1609U4M 512Kx36 & 1Mx18 & 2Mx9 Quadruple-II+ BL4 SRAM w/ ODT****165FBGA PKG Pin Configurations - S7T1609U4M (2Mx9) - Top View**

| | 1 | 2 | 3 | 4 | 5 | 6 | 7 | 8 | 9 | 10 | 11 |
|----------|--------------------------|------------------|------------------|-----------------------|-----------------|-----------------------|------------------------|-----------------------|------------------|------------------|-----|
| A | $\overline{\text{CQ}}$ | NC/SA* | SA | $\overline{\text{W}}$ | NC | $\overline{\text{K}}$ | NC | $\overline{\text{R}}$ | SA | NC/SA* | CQ |
| B | NC | NC | NC | SA | NC | K | $\overline{\text{BW}}$ | SA | NC | NC | Q4 |
| C | NC | NC | NC | V _{SS} | SA | NC | SA | V _{SS} | NC | NC | D4 |
| D | NC | D5 | NC | V _{SS} | V _{SS} | V _{SS} | V _{SS} | V _{SS} | NC | NC | NC |
| E | NC | NC | Q5 | V _{DDQ} | V _{SS} | V _{SS} | V _{SS} | V _{DDQ} | NC | D3 | Q3 |
| F | NC | NC | NC | V _{DDQ} | V _{DD} | V _{SS} | V _{DD} | V _{DDQ} | NC | NC | NC |
| G | NC | D6 | Q6 | V _{DDQ} | V _{DD} | V _{SS} | V _{DD} | V _{DDQ} | NC | NC | NC |
| H | $\overline{\text{Doff}}$ | V _{REF} | V _{DDQ} | V _{DDQ} | V _{DD} | V _{SS} | V _{DD} | V _{DDQ} | V _{DDQ} | V _{REF} | ZQ |
| J | NC | NC | NC | V _{DDQ} | V _{DD} | V _{SS} | V _{DD} | V _{DDQ} | NC | Q2 | D2 |
| K | NC | NC | NC | V _{DDQ} | V _{DD} | V _{SS} | V _{DD} | V _{DDQ} | NC | NC | NC |
| L | NC | Q7 | D7 | V _{DDQ} | V _{SS} | V _{SS} | V _{SS} | V _{DDQ} | NC | NC | Q1 |
| M | NC | NC | NC | V _{SS} | V _{SS} | V _{SS} | V _{SS} | V _{SS} | NC | NC | D1 |
| N | NC | D8 | NC | V _{SS} | SA | SA | SA | V _{SS} | NC | NC | NC |
| P | NC | NC | Q8 | SA | SA | QVLD | SA | SA | NC | D0 | Q0 |
| R | TDO | TCK | SA | SA | SA | ODT | SA | SA | SA | TMS | TDI |

Notes: 1. * Checked No Connect(NC) pins are reserved for higher density address, i.e. 10A for 36Mb, 2A for 72Mb, 7A for 144Mb.
2. $\overline{\text{BW}}$ controls write to D0:D8.

Pin Name

| Symbol | Pin Numbers | Description | Note |
|----------------------------|--|--|------|
| K, $\overline{\text{K}}$ | 6B, 6A | Input Clock | 1 |
| QVLD | 6P | Q Valid Output | |
| ODT | 6R | On die termination input | |
| CQ, $\overline{\text{CQ}}$ | 11A, 1A | Output Echo Clock | |
| $\overline{\text{Doff}}$ | 1H | DLL Disable when low | |
| SA | 3A,9A,4B,8B,5C,7C,5N-7N,4P,5P,7P,8P,3R-5R,7R-9R | Address Inputs | |
| D0-8 | 11M,11J,10E,11C,2D,2G,3L,2N,10P | Data Inputs | |
| Q0-8 | 11L,10J,11E,11B,3E,3G,2L,3P,11P | Data Outputs | |
| $\overline{\text{W}}$ | 4A | Write Control Pin, active when low | |
| $\overline{\text{R}}$ | 8A | Read Control Pin, active when low | |
| $\overline{\text{BW}}$ | 7B | Block Write Control Pin, active when low | |
| V _{REF} | 2H,10H | Input Reference Voltage | |
| ZQ | 11H | Output Driver Impedance Control Input | 2 |
| V _{DD} | 5F,7F,5G,7G,5H,7H,5J,7J,5K,7K | Power Supply (1.8 V) | |
| V _{DDQ} | 4E,8E,4F,8F,4G,8G,3H,4H,8H,9H,4J,8J,4K,8K,4L,8L | Output Power Supply (1.5V or 1.8V) | |
| V _{SS} | 4C,8C,4D-8D,5E-7E,6F,6G,6H,6J,6K,5L-7L,4M-8M,4N,8N | Ground | |
| TMS | 10R | JTAG Test Mode Select | |
| TDI | 11R | JTAG Test Data Input | |
| TCK | 2R | JTAG Test Clock | |
| TDO | 1R | JTAG Test Data Output | |
| NC | 2A,5A,7A,10A,1B,2B,3B,5B,9B,10B,1C,2C,3C,6C,9C,10C,1D,3D,9D,10D,11D,1E,2E,9E,1F,2F,3F,9F,10F,11F,1G,9G,10G,11G,1J,2J,3J,9J,1K,2K,3K,9K,10K,11K,1L,9L,10L,1M,2M,3M,9M | No Connect | 3 |

Notes: 1. K or $\overline{\text{K}}$ cannot be set to V_{REF} voltage.
2. When ZQ pin is directly connected to V_{DD} output impedance is set to minimum value and it cannot be connected to ground or left unconnected.
3. Not connected to chip pad internally.

S7T1636U4M S7T1618U4M S7T1609U4M 512Kx36 & 1Mx18 & 2Mx9 Quadruple-II+ BL4 SRAM w/ ODT

Read Operations

Read cycles are initiated by activating \overline{R} at the rising edge of the positive input clock K. Address is presented and stored in the read address register synchronized with K clock. For 4-bit burst DDR operation, it will access four 36-bit, 18-bit or 9-bit data words with each read command.

The first pipelined data is transferred out of the device triggered by \overline{K} clock rising edge. Next burst data is triggered by the rising edge of following K clock rising edge. The process continues until all four data are transferred. Continuous read operations are initiated with \overline{K} clock rising edge. And pipelined data are transferred out of device on every rising edge of both K and \overline{K} clocks. Initial read data latency is 2.5 clock cycles when DLL is on.

When the \overline{R} is disabled after a read operation, the S7T1636U4M, S7T1618U4M and S7T1609U4M will first complete burst read operation before entering into deselect mode at the next K clock rising edge. Then output drivers disabled automatically to high impedance state.

Write Operations

Write cycles are initiated by activating \overline{W} at the rising edge of the positive input clock K. Address is presented and stored in the write address register synchronized with K clock. For 4-bit burst DDR operation, it will write four 36-bit, 18-bit or 9-bit data words with each write command.

The first "late" data is transferred and registered in to the device synchronous with next K clock rising edge. Next burst data is transferred and registered synchronous with following \overline{K} clock rising edge. The process continues until all four data are transferred and registered. Continuous write operations are initiated with K rising edge. And "late write" data is presented to the device on every rising edge of both K and \overline{K} clocks.

The device disregards input data presented on the same cycle \overline{W} disabled. When the \overline{W} is disabled after a write operation, the S7T1636U4M, S7T1618U4M and S7T1609U4M will first complete burst write operation before entering into deselect mode at the next K clock rising edge.

The S7T1636U4M, S7T1618U4M and S7T1609U4M support byte write operations. With activating \overline{BW}_0 or \overline{BW}_1 (\overline{BW}_2 or \overline{BW}_3) in write cycle, only one byte of input data is presented. In S7T1618U4M, \overline{BW}_0 controls write operation to D0:D8, \overline{BW}_1 controls write operation to D9:D17. And in S7T1636U4M \overline{BW}_2 controls write operation to D18:D26, \overline{BW}_3 controls write operation to D27:D35. And in S7T1609U4M \overline{BW} controls write operation to D0:D8.

Depth Expansion

Separate input and output ports enables easy depth expansion. Each port can be selected and deselected independently and read and write operation do not affect each other. Before chip deselected, all read and write pending operations are completed.

Programmable Impedance Output Buffer Operation

The designer can program the SRAM's output buffer impedance by terminating the ZQ pin to Vss through a precision resistor (RQ). The allowable range of RQ is between 175Ω and 350Ω. The value of RQ (within 15%) is five times the output impedance desired. For example, 250Ω resistor will give an output impedance of 50Ω. Impedance updates occur early in cycles that do not activate the outputs, such as deselect cycles.

In all cases impedance updates are transparent to the user and do not produce access time "push-outs" or other anomalous behavior in the SRAM.

To guarantee optimum output driver impedance after power up, the SRAM needs 1024 non-read cycles.

Output Valid Pin (QVLD)

The Q Valid indicates valid output data. QVLD is actiated half cycle before the read data for the receiver to be ready for capturing the data. QVLD is edge aligned with CQ and \overline{CQ}

Echo clock operation

To assure the output traceability, the SRAM provides the output Echo clock, pair of compliment clock CQ and \overline{CQ} , which are synchronized with internal data output. Echo clocks run free during normal operation.

The Echo clock is triggered by internal output clock signal, and transferred to external through same structures as output driver.

S7T1636U4M S7T1618U4M S7T1609U4M 512Kx36 & 1Mx18 & 2Mx9 Quadruple-II+ BL4 SRAM w/ ODT

Clock Consideration

S7T1636U4M, S7T1618U4M and S7T1609U4M utilizes internal DLL (Delay-Locked Loops) for maximum output data valid window. It can be placed into a stopped-clock state to minimize power with a modest restart time of 2048 clock cycles. Circuitry automatically resets the DLL when absence of input clock is detected.

On Die Termination Impedance

S7T1636U4M, S7T1618U4M and S7T1609U4M support On Die Termination (ODT). The input signal level on ODT pin determines the impedance range of on die termination. If ODT pin is tied High, termination impedance will be in high range which is equal to $RQ \times 0.6$ for $175\Omega \leq RQ \leq 350\Omega$. If ODT pin is tied low, termination impedance will be in low range which is equal to $RQ \times 0.3$ for $175\Omega \leq RQ \leq 250\Omega$. Default impedance range when ODT pin is not connected is high.

Power-Up/Power-Down Supply Voltage Sequencing

The following power-up supply voltage application is recommended: V_{SS} , V_{DD} , V_{DDQ} , V_{REF} , then V_{IN} . V_{DD} and V_{DDQ} can be applied simultaneously, as long as V_{DDQ} does not exceed V_{DD} by more than 0.5V during power-up. The following power-down supply voltage removal sequence is recommended: V_{IN} , V_{REF} , V_{DDQ} , V_{DD} , V_{SS} . V_{DD} and V_{DDQ} can be removed simultaneously, as long as V_{DDQ} does not exceed V_{DD} by more than 0.5V during power-down.

Detail Specification of Power-Up Sequence in Quadruple-II+ SRAM

Quadruple-II+ SRAMs must be powered up and initialized in a predefined manner to prevent undefined operations.

• Power-Up Sequence

1. Apply power and keep \overline{Doff} at low state (All other inputs may be undefined)
 - Apply V_{DD} before V_{DDQ}
 - Apply V_{DDQ} before V_{REF} or the same time with V_{REF}
2. Just after the stable power and clock (K, \overline{K}), take \overline{Doff} to be high.
3. The additional 2048 cycles of clock input is required to lock the DLL after enabling DLL

* **Notes:** If you want to tie up the \overline{Doff} pin to High with unstable clock, then you must stop the clock for a few seconds (Min. 30ns) to reset the DLL after it become a stable clock status.

• DLL Constraints

1. DLL uses K clock as its synchronizing input, the input should have low phase jitter which is specified as TK_{var} .
2. The lower end of the frequency at which the DLL can operate is 120MHz.
3. If the incoming clock is unstable and the DLL is enabled, then the DLL may lock onto a wrong frequency and this may cause the failure in the initial stage.

S7T1636U4M
S7T1618U4M
S7T1609U4M 512Kx36 & 1Mx18 & 2Mx9 Quadruple-II+ BL4 SRAM w/ ODT

Power up & Initialization Sequence ($\overline{\text{Doff}}$ pin controlled)

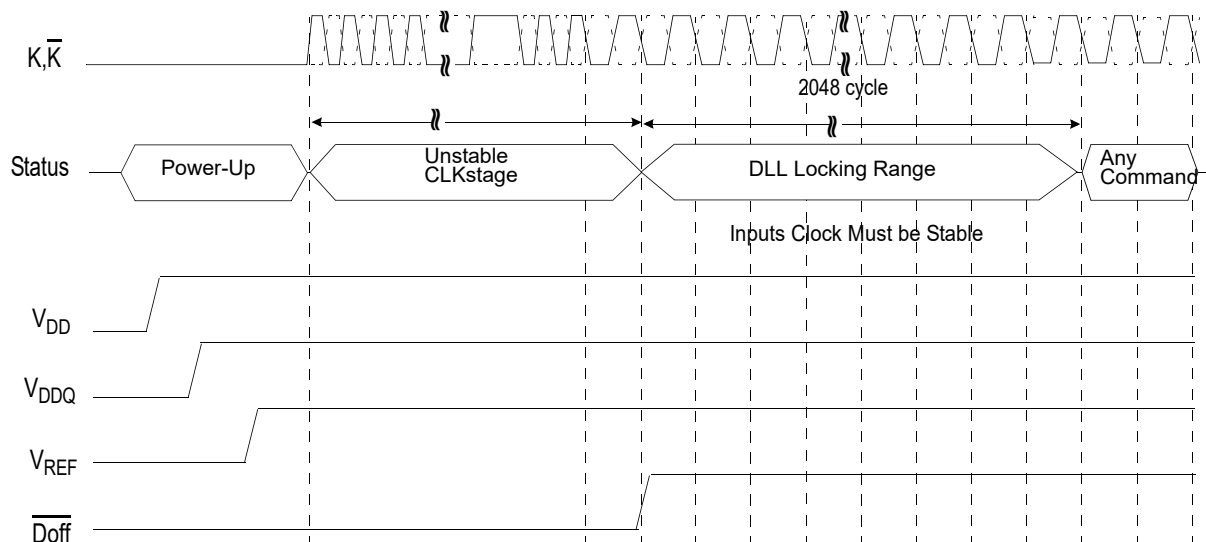

Power up & Initialization Sequence ($\overline{\text{Doff}}$ pin Fixed high, Clock controlled)

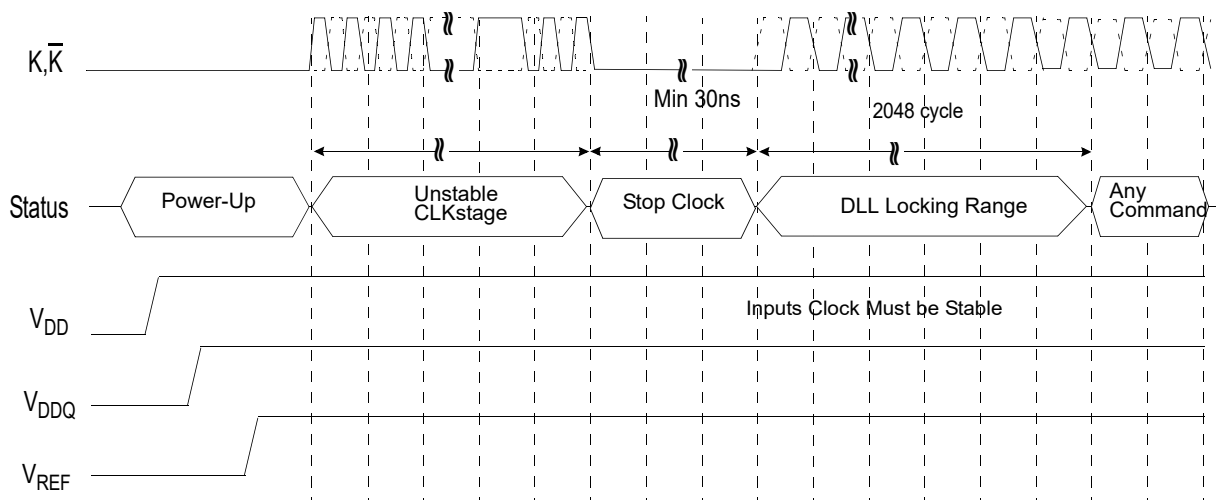

* **Notes:** When the operating frequency is changed, It is required to reset DLL again.
 After resetting DLL, the minimum 2048 cycles of clock input is needed to lock the DLL.

S7T1636U4M
S7T1618U4M
S7T1609U4M 512Kx36 & 1Mx18 & 2Mx9 Quadruple-II+ BL4 SRAM w/ ODT

Truth Tables
SYNCHRONOUS TRUTH TABLE

| K | \bar{R} | \bar{W} | D | | | | Q | | | | OPERATION |
|---------|----------------|----------------|-----------------------------------|-----------------------------------|-----------------------------------|-----------------------------------|------------------------------------|------------------------------------|------------------------------------|------------------------------------|--------------|
| | | | D(A1) | D(A2) | D(A3) | D(A4) | Q(A1) | Q(A2) | Q(A3) | Q(A4) | |
| Stopped | X | X | Previous state | Previous state | Previous state | Previous state | Previous state | Previous state | Previous state | Previous state | Clock Stop |
| ↑ | H | H | X | X | X | X | High-Z | High-Z | High-Z | High-Z | No Operation |
| ↑ | L ⁴ | X | X | X | X | X | Q _{OUT} at $\bar{K}(t+2)$ | Q _{OUT} at $\bar{K}(t+3)$ | Q _{OUT} at $\bar{K}(t+3)$ | Q _{OUT} at $\bar{K}(t+4)$ | Read |
| ↑ | H ⁵ | L ⁴ | D _{in} at $\bar{K}(t+1)$ | D _{in} at $\bar{K}(t+1)$ | D _{in} at $\bar{K}(t+2)$ | D _{in} at $\bar{K}(t+2)$ | X | X | X | X | Write |

- Notes:** 1. X means "Don't Care".
2. The rising edge of clock is symbolized by (↑).
3. Before enter into clock stop status, all pending read and write operations will be completed.
4. This signal was HIGH on previous K clock rising edge. Initiating consecutive READ or WRITE operations on consecutive K clock rising edges is not permitted. The device will ignore the second request.
5. If this signal was LOW to initiated the previous cycle, this signal becomes a don't care for this operation however it is strongly recommended that this signal is brought HIGH as shown in the truth table.

WRITE TRUTH TABLE (x18)

| K | \bar{K} | \bar{BW}_0 | \bar{BW}_1 | Operation |
|---|-----------|--------------|--------------|---------------------------------|
| ↑ | | L | L | WRITE ALL BYTES (K↑) |
| | ↑ | L | L | WRITE ALL BYTES (\bar{K} ↑) |
| ↑ | | L | H | WRITE BYTE 0 (K↑) |
| | ↑ | L | H | WRITE BYTE 0 (\bar{K} ↑) |
| ↑ | | H | L | WRITE BYTE 1 (K↑) |
| | ↑ | H | L | WRITE BYTE 1 (\bar{K} ↑) |
| ↑ | | H | H | WRITE NOTHING (K↑) |
| | ↑ | H | H | WRITE NOTHING (\bar{K} ↑) |

- Notes:** 1. X means "Don't Care".
2. All inputs in this table must meet setup and hold time around the rising edge of input clock K or \bar{K} (↑).
3. Assumes a WRITE cycle was initiated.
4. This table illustrates operation for x18 devices. x9 device operation is similar except that \bar{BW} controls D0:D8.

WRITE TRUTH TABLE (x36)

| K | \bar{K} | \bar{BW}_0 | \bar{BW}_1 | \bar{BW}_2 | \bar{BW}_3 | Operation |
|---|-----------|--------------|--------------|--------------|--------------|---|
| ↑ | | L | L | L | L | WRITE ALL BYTES (K↑) |
| | ↑ | L | L | L | L | WRITE ALL BYTES (\bar{K} ↑) |
| ↑ | | L | H | H | H | WRITE BYTE 0 (K↑) |
| | ↑ | L | H | H | H | WRITE BYTE 0 (\bar{K} ↑) |
| ↑ | | H | L | H | H | WRITE BYTE 1 (K↑) |
| | ↑ | H | L | H | H | WRITE BYTE 1 (\bar{K} ↑) |
| ↑ | | H | H | L | L | WRITE BYTE 2 and BYTE 3 (K↑) |
| | ↑ | H | H | L | L | WRITE BYTE 2 and BYTE 3 (\bar{K} ↑) |
| ↑ | | H | H | H | H | WRITE NOTHING (K↑) |
| | ↑ | H | H | H | H | WRITE NOTHING (\bar{K} ↑) |

- Notes:** 1. X means "Don't Care".
2. All inputs in this table must meet setup and hold time around the rising edge of input clock K or \bar{K} (↑).
3. Assumes a WRITE cycle was initiated.

S7T1636U4M

S7T1618U4M

S7T1609U4M 512Kx36 & 1Mx18 & 2Mx9 Quadruple-II+ BL4 SRAM w/ ODT

Absolute Maximum Ratings*

| Parameter | Symbol | Rating | Unit | |
|--|-------------------------|------------------------------|---------------------|----|
| Voltage on V _{DD} Supply Relative to V _{SS} | V _{DD} | -0.5 to 2.9 | V | |
| Voltage on V _{DDQ} Supply Relative to V _{SS} | V _{DDQ} | -0.5 to V _{DD} | V | |
| Voltage on Input Pin Relative to V _{SS} | V _{IN} | -0.5 to V _{DD} +0.3 | V | |
| Storage Temperature | T _{STG} | -65 to 150 | °C | |
| Operating Temperature | Commercial / Industrial | T _{OPR} | 0 to 70 / -40 to 85 | °C |
| Storage Temperature Range Under Bias | T _{BIAS} | -10 to 85 | °C | |

***Note:** 1. Stresses greater than those listed under "Absolute Maximum Ratings" may cause permanent damage to the device. This is a stress rating only and functional operation of the device at these or any other conditions above those indicated in the operating sections of this specification is not implied. Exposure to absolute maximum rating conditions for extended periods may affect reliability.

OPERATING CONDITIONS (0°C ≤ T_A ≤ 70°C)

| Parameter | Symbol | Min | Typ | Max | Unit |
|--|----------------------|------------------------|------|------------------------|------|
| Supply Voltage | V _{DD} | 1.7 | 1.8 | 1.9 | V |
| | V _{DDQ} | 1.4 | 1.5 | 1.9 | V |
| Reference Voltage | V _{REF} | 0.7 | 0.75 | 0.95 | V |
| Input Low Voltage(DC) ^{2,3)} | V _{IL} (DC) | -0.3 | - | V _{REF} - 0.1 | V |
| Input High Voltage(DC) ^{2,4)} | V _{IH} (DC) | V _{REF} + 0.1 | - | V _{DDQ} + 0.3 | V |
| Input Low Voltage(AC) ^{6,7)} | V _{IL} (AC) | - | - | V _{REF} - 0.2 | V |
| Input High Voltage(AC) ^{6,7)} | V _{IH} (AC) | V _{REF} + 0.2 | - | - | V |

- Note:** 1. V_{DDQ} must not exceed V_{DD} during normal operation.
2. These are DC test criteria. DC design criteria is V_{REF}±50mV. The AC V_{IH}/V_{IL} levels are defined separately for measuring timing parameters.
3. V_{IL} (Min)DC=-0.3V, V_{IL} (Min)AC=-1.5V(pulse width ≤ 3ns).
4. V_{IH} (Max)DC=V_{DDQ}+0.3V, V_{IH} (Max)AC=V_{DDQ}+0.85V(pulse width ≤ 3ns).
5. Overshoot : V_{IH} (AC) ≤ V_{DDQ}+0.5V for t ≤ 50% t_{KHKH}(MIN).
Undershoot: V_{IL} (AC) ≤ V_{SS}-0.5V for t ≤ 50% t_{KHKH}(MIN).
6. This condition is for AC function test only, not for AC parameter test.
7. To maintain a valid level, the transiting edge of the input must:
a) Sustain a constant slew rate from the current AC level through the target AC level, V_{IL}(AC) or V_{IH}(AC)
b) Reach at least the target AC level
c) After the AC target level is reached, continue to maintain at least the target DC level, V_{IL}(DC) or V_{IH}(DC)

S7T1636U4M**S7T1618U4M****S7T1609U4M 512Kx36 & 1Mx18 & 2Mx9 Quadruple-II+ BL4 SRAM w/ ODT****DC Electrical Characteristics**

| Parameter | Symbol | test Conditions | Min | Max | Unit | Notes | |
|-------------------------|--------|--|-------------|-------------|------|-------|-----|
| Input Leakage Current | IIL | VDD=Max; VIN=VSS to VDDQ | -2 | +2 | μA | | |
| Output Leakage Current | IOL | Output Disabled, | -2 | +2 | μA | | |
| Operating Current (x36) | Icc | VDD=Max, IOUT=0mA Cycle Time ≥ tKHKH Min | -55 | - | 980 | mA | 1,4 |
| | | | -50 | - | 915 | | |
| | | | -45 | - | 850 | | |
| | | | -40 | | 785 | | |
| Operating Current (x18) | Icc | VDD=Max, IOUT=0mA Cycle Time ≥ tKHKH Min | -55 | - | 760 | mA | 1,4 |
| | | | -50 | - | 715 | | |
| | | | -45 | - | 670 | | |
| | | | -40 | | 625 | | |
| Operating Current (x9) | Icc | VDD=Max, IOUT=0mA Cycle Time ≥ tKHKH Min | -55 | - | 730 | mA | 1,4 |
| | | | -50 | - | 695 | | |
| | | | -45 | - | 655 | | |
| | | | -40 | | 615 | | |
| Standby Current (NOP) | ISB1 | Device deselected, IOUT=0mA, f=Max, All Inputs ≤ 0.2V or ≥ VDD-0.2V | -55 | | 340 | mA | 1,5 |
| | | | -50 | | 330 | | |
| | | | -45 | | 320 | | |
| | | | -40 | | 310 | | |
| Output High Voltage | VOH1 | | VDDQ/2-0.12 | VDDQ/2+0.12 | V | 2,6 | |
| Output Low Voltage | VOL1 | | VDDQ/2-0.12 | VDDQ/2+0.12 | V | 2,6 | |
| Output High Voltage | VOH2 | IOH=-1.0mA | VDDQ-0.2 | VDDQ | V | 3 | |
| Output Low Voltage | VOL2 | IOL=1.0mA | VSS | 0.2 | V | 3 | |

Notes: 1. Minimum cycle. IOUT=0mA.2. $|I_{OH}| = (V_{DDQ}/2)/(RQ/5) \pm 15\%$ for $175\Omega \leq RQ \leq 350\Omega$. $|I_{OL}| = (V_{DDQ}/2)/(RQ/5) \pm 15\%$ for $175\Omega \leq RQ \leq 350\Omega$.

3. Minimum Impedance Mode when ZQ pin is connected to VDD.

4. Operating current is calculated with 50% read cycles and 50% write cycles.

5. Standby Current is only after all pending read and write burst operations are completed.

6. Programmable Impedance Mode.

S7T1636U4M
S7T1618U4M
S7T1609U4M 512Kx36 & 1Mx18 & 2Mx9 Quadruple-II+ BL4 SRAM w/ ODT

AC Timing Characteristics

| Parameter | Symbol | -55 | | -50 | | -45 | | -40 | | Unit | Notes |
|--|--|-------|------|-------|------|-------|------|-------|------|-------|-------|
| | | Min | Max | Min | Max | Min | Max | Min | Max | | |
| Clock | | | | | | | | | | | |
| Clock Cycle Time (K, \bar{K}) | t _{KHKH} | 1.81 | 8.40 | 2.0 | 8.40 | 2.22 | 8.40 | 2.5 | 8.40 | ns | |
| Clock Phase Jitter (K, \bar{K}) | t _{K var} | | 0.15 | | 0.15 | | 0.15 | | 0.15 | ns | 4 |
| Clock High Time (K, \bar{K}) | t _{KHKL} | 0.4 | | 0.4 | | 0.4 | | 0.4 | | ns | |
| Clock Low Time (K, \bar{K}) | t _{KLKH} | 0.4 | | 0.4 | | 0.4 | | 0.4 | | ns | |
| Clock to $\bar{C}lock$ ($K\uparrow \rightarrow \bar{K}\uparrow$) | t _{KH\bar{K}H} | 0.77 | | 0.85 | | 0.94 | | 1.06 | | ns | |
| DLL Lock Time (K) | t _{K lock} | 2048 | | 2048 | | 2048 | | 2048 | | cycle | 5 |
| K Static to DLL reset | t _{K reset} | 30 | | 30 | | 30 | | 30 | | ns | |
| Output Times | | | | | | | | | | | |
| K, \bar{K} High to Output Valid | t _{KHQV} | | 0.45 | | 0.45 | | 0.45 | | 0.45 | ns | |
| K, \bar{K} High to Output Hold | t _{KHQX} | -0.45 | | -0.45 | | -0.45 | | -0.45 | | ns | |
| K, \bar{K} High to Echo Clock Valid | t _{KHCQV} | | 0.45 | | 0.45 | | 0.45 | | 0.45 | ns | |
| K, \bar{K} High to Echo Clock Hold | t _{KHCQX} | -0.45 | | -0.45 | | -0.45 | | -0.45 | | ns | |
| CQ, $\bar{C}Q$ High to Output Valid | t _{CQHQV} | | 0.15 | | 0.15 | | 0.15 | | 0.2 | ns | |
| CQ, $\bar{C}Q$ High to Output Hold | t _{CQHQX} | -0.15 | | -0.15 | | -0.15 | | -0.2 | | ns | |
| CQ High to $\bar{C}Q$ High | t _{CQH$\bar{C}Q$H} | 0.655 | | 0.75 | | 0.85 | | 1.0 | | | 6 |
| K, \bar{K} , High to Output High-Z | t _{KHZ} | | 0.45 | | 0.45 | | 0.45 | | 0.45 | ns | |
| K, \bar{K} , High to Output Low-Z | t _{KLZ} | -0.45 | | -0.45 | | -0.45 | | -0.45 | | ns | |
| CQ, $\bar{C}Q$ High to QVLD Valid | t _{QVLD} | -0.15 | 0.15 | -0.15 | 0.15 | -0.15 | 0.15 | -0.2 | 0.2 | ns | |
| Setup Times | | | | | | | | | | | |
| Address valid to K rising edge | t _{AVKH} | 0.23 | | 0.25 | | 0.275 | | 0.40 | | ns | |
| Control inputs valid to K rising edge | t _{IVKH} | 0.23 | | 0.25 | | 0.275 | | 0.40 | | ns | 2 |
| Data-in valid to K, \bar{K} rising edge | t _{DVKH} | 0.18 | | 0.20 | | 0.22 | | 0.28 | | ns | |
| Hold Times | | | | | | | | | | | |
| K rising edge to address hold | t _{KHAX} | 0.23 | | 0.25 | | 0.275 | | 0.40 | | ns | |
| K rising edge to control inputs hold | t _{KHIX} | 0.23 | | 0.25 | | 0.275 | | 0.40 | | ns | |
| K, \bar{K} rising edge to data-in hold | t _{KHDX} | 0.18 | | 0.20 | | 0.22 | | 0.28 | | ns | |

- Notes:**
- All address inputs must meet the specified setup and hold times for all latching clock edges.
 - Control signals are R/W and LD.
However BWx does not apply to this parameters. $\bar{B}Wx$ signals obey the data setup and hold times.
 - To avoid bus contention, at a given voltage and temperature t_{KLZ} is bigger than t_{KHZ}.
The specs as shown do not imply bus contention because t_{KLZ} is a MIN parameter that is worst case at totally different test conditions (0°C, 1.9V) than t_{KHZ}, which is a MAX parameter (worst case at 70°C, 1.7V)
It is not possible for two SRAMs on the same board to be at such different voltage and temperature.
 - Clock phase jitter is the variance from clock rising edge to the next expected clock rising edge.
 - V_{dd} slew rate must be less than 0.1V DC per 50 ns for DLL lock retention. DLL lock time begins once V_{dd} and input clock are stable.
 - This parameter is extrapolated from the input timing parameters (t_{KH \bar{K} H} - 200ps where 200ps is the internal jitter.) This parameter is only guaranteed by design and not tested in production.

S7T1636U4M

S7T1618U4M

S7T1609U4M 512Kx36 & 1Mx18 & 2Mx9 Quadruple-II+ BL4 SRAM w/ ODT

Thermal Resistance

| Parameter | Symbol | Typical | Unit | Notes |
|---------------------|---------------|---------|----------------------|-------|
| Junction to Ambient | θ_{JA} | 16.3 | $^{\circ}\text{C/W}$ | |
| Junction to Case | θ_{JC} | 2.3 | $^{\circ}\text{C/W}$ | |

Note: Junction temperature is a function of on-chip power dissipation, package thermal impedance, mounting site temperature and mounting site thermal impedance. $T_J = T_A + P_D \times \theta_{JA}$

Pin Capacitance

| Parameter | Symbol | Test Condition | Typ | Max | Unit | Notes |
|-----------------------------------|------------------|----------------------|-----|-----|------|-------|
| Address Control Input Capacitance | C _{IN} | V _{IN} =0V | 3.5 | 4 | pF | |
| Input and Output Capacitance | C _{OUT} | V _{OUT} =0V | 4 | 5 | pF | |
| Clock Capacitance | C _{CLK} | - | 3 | 4 | pF | |

Note: 1. Parameters are tested with R_Q=250 Ω and V_{DDQ}=1.5V.

2. Periodically sampled and not 100% tested.

AC Test Conditions

| Parameter | Symbol | Value | Unit |
|-------------------------------|----------------------------------|---------------------|------|
| Core Power Supply Voltage | V _{DD} | 1.7~1.9 | V |
| Output Power Supply Voltage | V _{DDQ} | 1.4~1.9 | V |
| Input High/Low Level | V _{IH} /V _{IL} | 1.25/0.25 | V |
| Input Reference Level | V _{REF} | 0.75 | V |
| Input Rise/Fall Time | T _R /T _F | 0.3/0.3 | ns |
| Output Timing Reference Level | | V _{DDQ} /2 | V |

Note: Parameters are tested with R_Q=250 Ω

AC Test Output Load

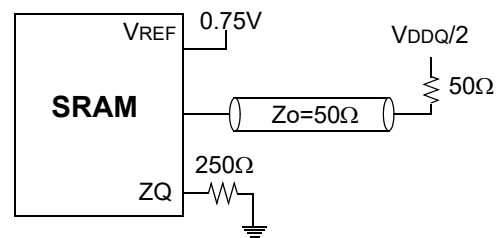

S7T1636U4M
S7T1618U4M
S7T1609U4M 512Kx36 & 1Mx18 & 2Mx9 Quadruple-II+ BL4 SRAM w/ ODT

Application Information

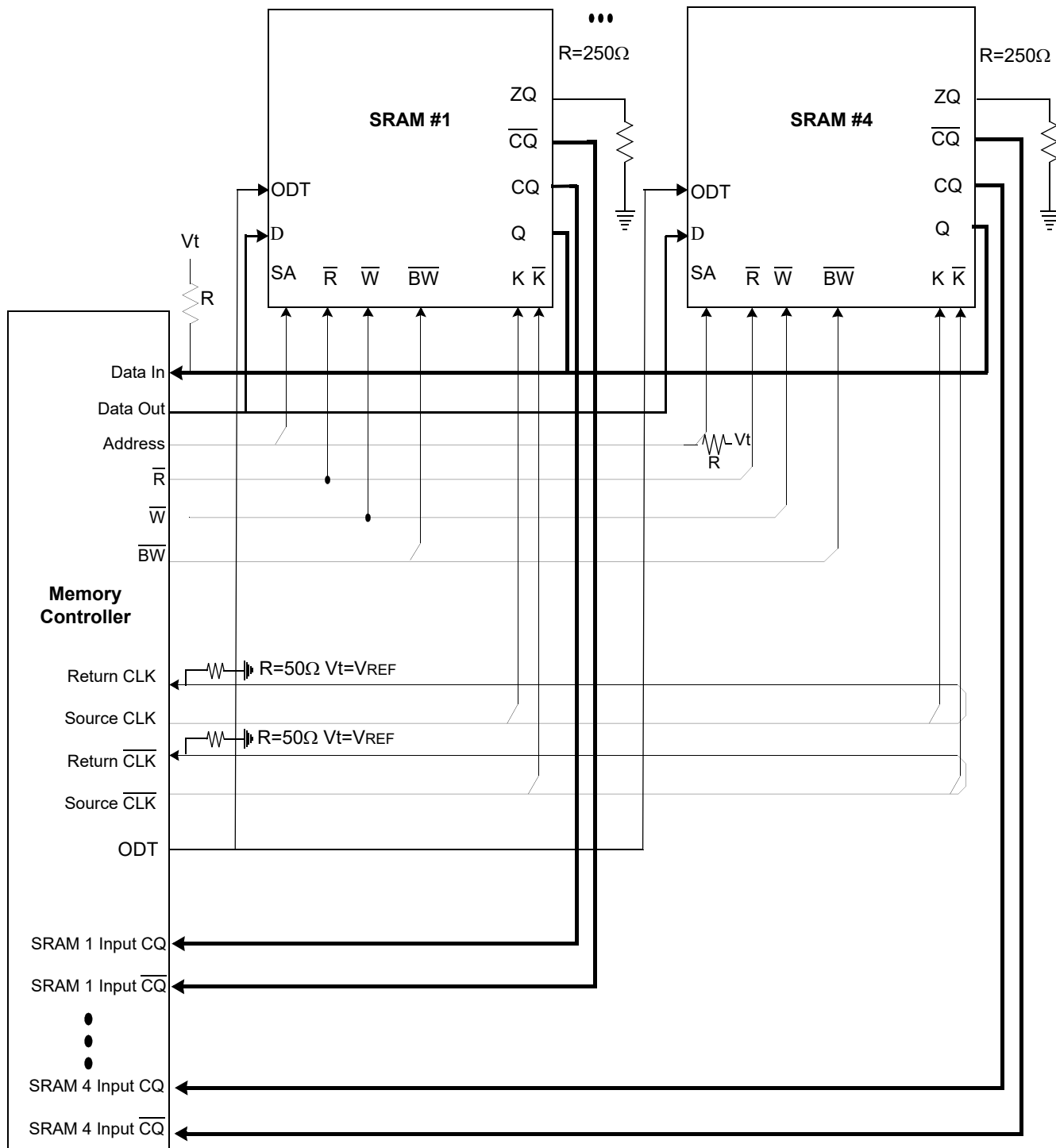

S7T1636U4M

S7T1618U4M

S7T1609U4M 512Kx36 & 1Mx18 & 2Mx9 Quadruple-II+ BL4 SRAM w/ ODT

TIMING WAVE FORMS OF READ AND NOP

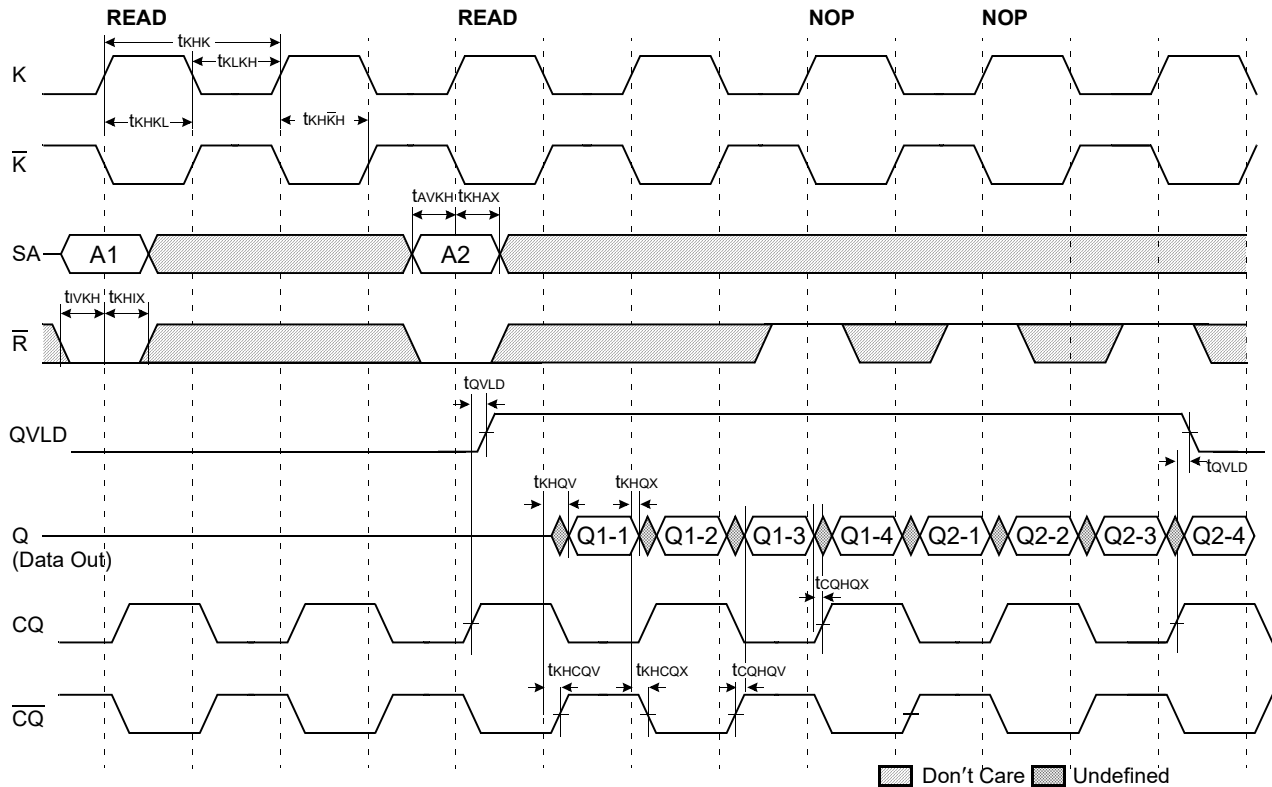

- Note:**
1. Q1-1 refers to output from address A1+0, Q1-2 refers to output from address A1+1 i.e. the next internal burst address following A1+0.
 2. Outputs are disabled one cycle after a NOP.

TIMING WAVE FORMS OF WRITE AND NOP

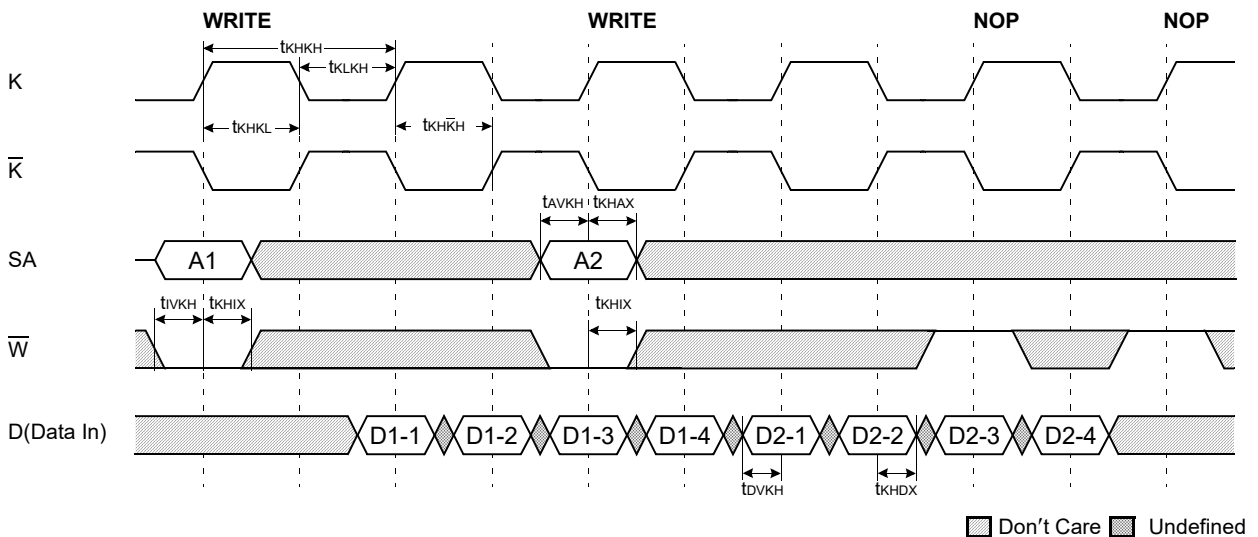

- Note:**
1. D1-1 refers to input to address A1+0, D1-2 refers to input to address A1+1, i.e. the next internal burst address following A1+0.
 2. \bar{W} assumed active.

S7T1636U4M
S7T1618U4M
S7T1609U4M 512Kx36 & 1Mx18 & 2Mx9 Quadruple-II+ BL4 SRAM w/ ODT

TIMING WAVE FORMS OF READ, WRITE AND NOP

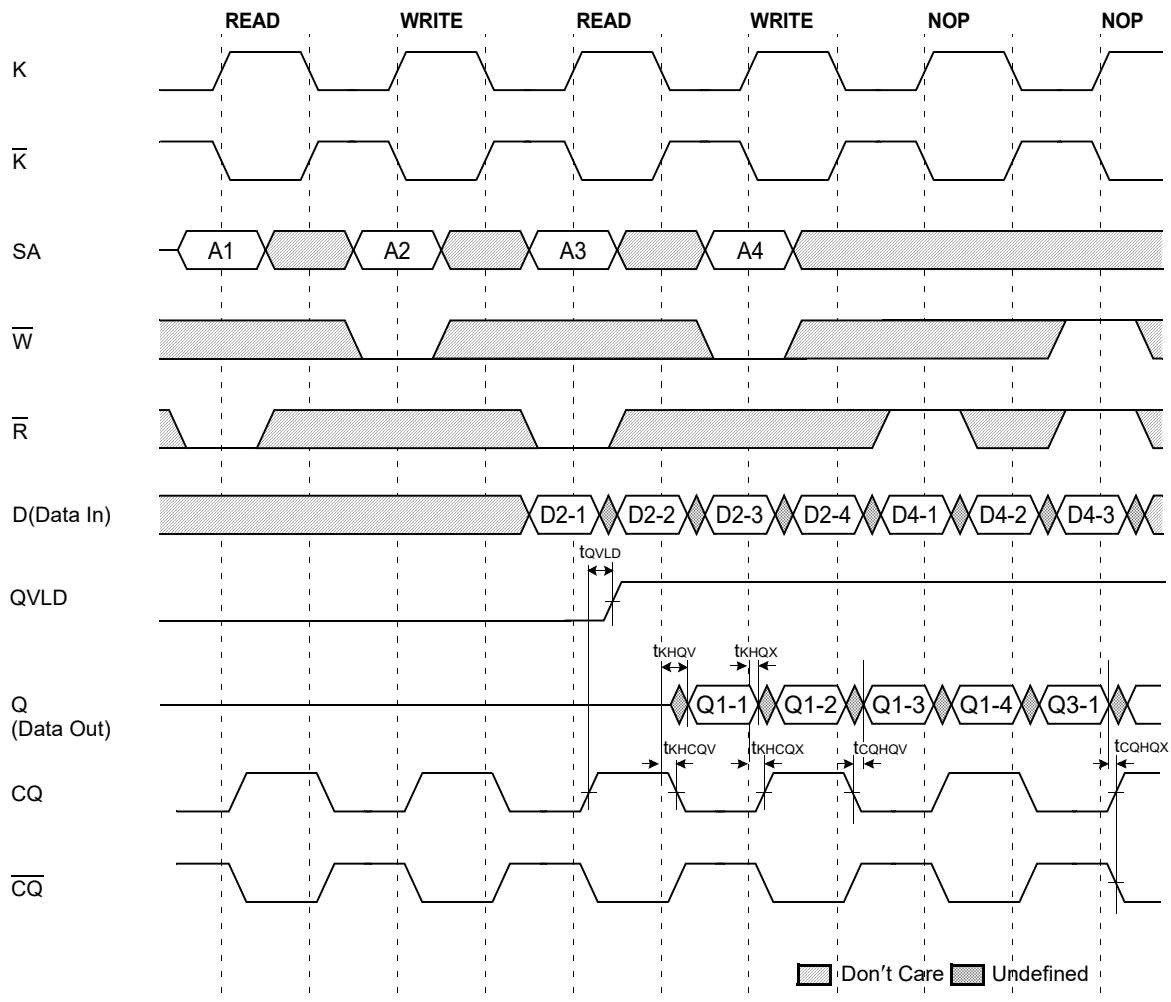

Note: 1. If address A3=A2, data Q3-1=D2-1, data Q3-2=D2-2, data Q3-3=D2-3, data Q3-4=D2-4
Write data is forwarded immediately as read results.
2. \bar{W} assumed active.

S7T1636U4M

S7T1618U4M

S7T1609U4M 512Kx36 & 1Mx18 & 2Mx9 Quadruple-II+ BL4 SRAM w/ ODT

IEEE 1149.1 Test Access Port and Boundary Scan-JTAG

This part contains an IEEE standard 1149.1 Compatible Test Access Port (TAP). The package pads are monitored by the Serial Scan circuitry when in test mode. This is to support connectivity testing during manufacturing and system diagnostics. Internal data is not driven out of the SRAM under JTAG control. In conformance with IEEE 1149.1, the SRAM contains a TAP controller, Instruction Register, Bypass Register and ID register. The TAP controller has a standard 16-state machine that resets internally upon power-up, therefore, TRST signal is not required. It is possible to use this device without utilizing the TAP. To disable the TAP controller without interfacing with normal operation of the SRAM, TCK must be tied to Vss to preclude mid level input. TMS and TDI are designed so an undriven input will produce a response identical to the application of a logic 1, and may be left unconnected. But they may also be tied to VDD through a resistor. TDO should be left unconnected.

JTAG Block Diagram

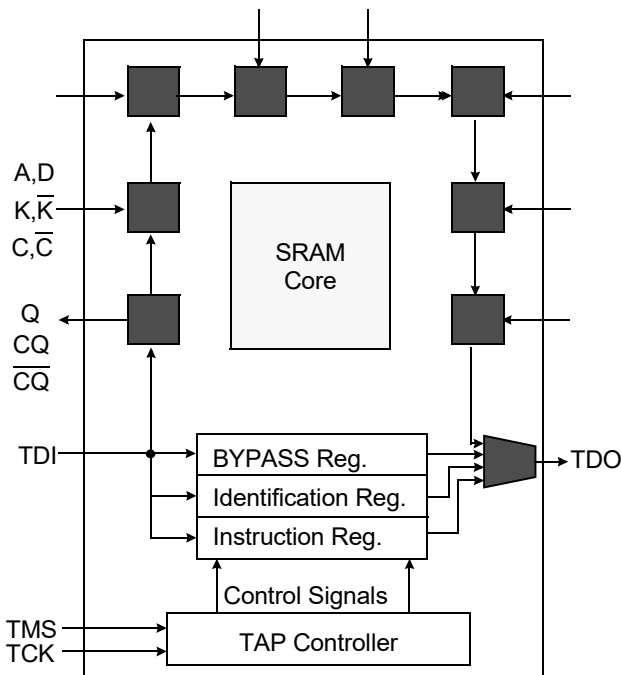

JTAG Instruction Coding

| IR2 | IR1 | IR0 | Instruction | TDO Output | Notes |
|-----|-----|-----|-------------|-------------------------|-------|
| 0 | 0 | 0 | EXTEST | Boundary Scan Register | 1 |
| 0 | 0 | 1 | IDCODE | Identification Register | 3 |
| 0 | 1 | 0 | SAMPLE-Z | Boundary Scan Register | 2 |
| 0 | 1 | 1 | RESERVED | Do Not Use | 6 |
| 1 | 0 | 0 | SAMPLE | Boundary Scan Register | 5 |
| 1 | 0 | 1 | RESERVED | Do Not Use | 6 |
| 1 | 1 | 0 | RESERVED | Do Not Use | 6 |
| 1 | 1 | 1 | BYPASS | Bypass Register | 4 |

NOTE:

1. Places DQs in Hi-Z in order to sample all input data regardless of other SRAM inputs. This instruction is not IEEE 1149.1 compliant.
2. Places DQs in Hi-Z in order to sample all input data regardless of other SRAM inputs.
3. TDI is sampled as an input to the first ID register to allow for the serial shift of the external TDI data.
4. Bypass register is initiated to Vss when BYPASS instruction is invoked. The Bypass Register also holds serially loaded TDI when exiting the Shift DR states.
5. SAMPLE instruction dose not places DQs in Hi-Z.
6. This instruction is reserved for future use.

TAP Controller State Diagram

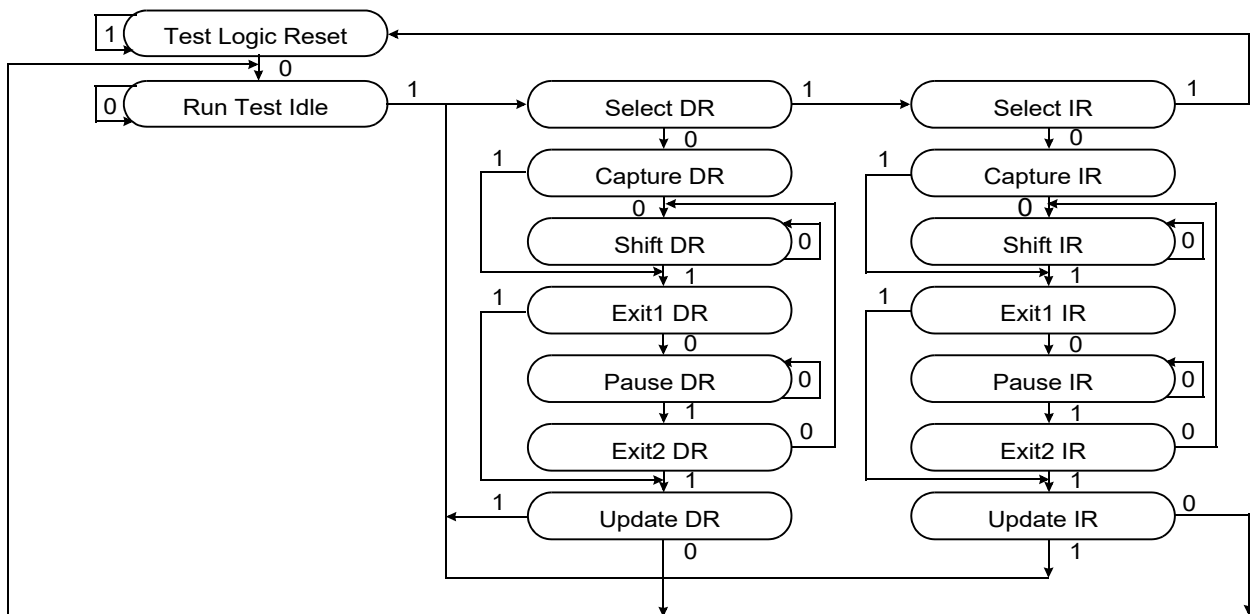

S7T1636U4M S7T1618U4M S7T1609U4M 512Kx36 & 1Mx18 & 2Mx9 Quadruple-II+ BL4 SRAM w/ ODT

Scan Register Definition

| Part | Instruction Register | Bypass Register | ID Register | Boundary Scan |
|--------------------------------|----------------------|-----------------|-------------|---------------|
| 512K x 36 1M x 18 2M x 9 | 3 bits | 1 bit | 32 bits | 109 bits |

ID Registration Definition

| Part | Revision Number (31:29) | Part Configuration (28:12) | Netsol JEDEC Code (11: 1) | Start Bit(0) |
|--------------------------------|----------------------------|-------------------------------|------------------------------|--------------|
| 512K x 36 1M x 18 2M x 9 | 000 | 00def0wx0tpqIb0s0 | 01111011001 | 1 |

Note: Part Configuration

/def=001 for 18Mb, /wx=11 for x36, 10 for x18, 00 for x9

/t=1 for DLL Ver., 0 for non-DLL Ver.

/q=1 for Quadruple, 0 for DDR

/b=1 for 4Bit Burst, 0 for 2Bit Burst

/p=1 for Quadruple-II+ or DDR-II+, 0 for Quadruple-II or DDR-II

/l=1 for 2.5 read latency, 0 for 2.0 read latency (applicable only to Quadruple-II+ and DDR-II+)

/s=1 for Separate I/O, 0 for Common I/O

Boundary Scan Exit Order

| Order | Pin ID |
|-------|--------|
| 1 | 6R |
| 2 | 6P |
| 3 | 6N |
| 4 | 7P |
| 5 | 7N |
| 6 | 7R |
| 7 | 8R |
| 8 | 8P |
| 9 | 9R |
| 10 | 11P |
| 11 | 10P |
| 12 | 10N |
| 13 | 9P |
| 14 | 10M |
| 15 | 11N |
| 16 | 9M |
| 17 | 9N |
| 18 | 11L |
| 19 | 11M |
| 20 | 9L |
| 21 | 10L |
| 22 | 11K |
| 23 | 10K |
| 24 | 9J |
| 25 | 9K |
| 26 | 10J |
| 27 | 11J |
| 28 | 11H |
| 29 | 10G |
| 30 | 9G |
| 31 | 11F |
| 32 | 11G |
| 33 | 9F |
| 34 | 10F |
| 35 | 11E |
| 36 | 10E |

| Order | Pin ID |
|-------|----------|
| 37 | 10D |
| 38 | 9E |
| 39 | 10C |
| 40 | 11D |
| 41 | 9C |
| 42 | 9D |
| 43 | 11B |
| 44 | 11C |
| 45 | 9B |
| 46 | 10B |
| 47 | 11A |
| 48 | Internal |
| 49 | 9A |
| 50 | 8B |
| 51 | 7C |
| 52 | 6C |
| 53 | 8A |
| 54 | 7A |
| 55 | 7B |
| 56 | 6B |
| 57 | 6A |
| 58 | 5B |
| 59 | 5A |
| 60 | 4A |
| 61 | 5C |
| 62 | 4B |
| 63 | 3A |
| 64 | 1H |
| 65 | 1A |
| 66 | 2B |
| 67 | 3B |
| 68 | 1C |
| 69 | 1B |
| 70 | 3D |
| 71 | 3C |
| 72 | 1D |

| Order | Pin ID |
|-------|--------|
| 73 | 2C |
| 74 | 3E |
| 75 | 2D |
| 76 | 2E |
| 77 | 1E |
| 78 | 2F |
| 79 | 3F |
| 80 | 1G |
| 81 | 1F |
| 82 | 3G |
| 83 | 2G |
| 84 | 1J |
| 85 | 2J |
| 86 | 3K |
| 87 | 3J |
| 88 | 2K |
| 89 | 1K |
| 90 | 2L |
| 91 | 3L |
| 92 | 1M |
| 93 | 1L |
| 94 | 3N |
| 95 | 3M |
| 96 | 1N |
| 97 | 2M |
| 98 | 3P |
| 99 | 2N |
| 100 | 2P |
| 101 | 1P |
| 102 | 3R |
| 103 | 4R |
| 104 | 4P |
| 105 | 5P |
| 106 | 5N |
| 107 | 5R |

Note: 1. NC pins are read as "X" (i.e. don't care.)

S7T1636U4M S7T1618U4M S7T1609U4M 512Kx36 & 1Mx18 & 2Mx9 Quadruple-II+ BL4 SRAM w/ ODT

JTAG DC Operating Conditions

| Parameter | Symbol | Min | Typ | Max | Unit | Note |
|---|-----------------|-----------------|-----|----------------------|------|------|
| Power Supply Voltage | V _{DD} | 1.7 | 1.8 | 1.9 | V | |
| Input High Level | V _{IH} | 1.3 | - | V _{DD} +0.3 | V | |
| Input Low Level | V _{IL} | -0.3 | - | 0.5 | V | |
| Output High Voltage (I _{OH} =-2mA) | V _{OH} | 1.4 | - | V _{DD} | V | |
| Output Low Voltage(I _{OL} =2mA) | V _{OL} | V _{SS} | - | 0.4 | V | |

Note: 1. The input level of SRAM pin is to follow the SRAM DC specification.

JTAG AC Test Conditions

| Parameter | Symbol | Min | Unit | Note |
|---|----------------------------------|---------|------|------|
| Input High/Low Level | V _{IH} /V _{IL} | 1.8/0.0 | V | |
| Input Rise/Fall Time | TR/TF | 1.0/1.0 | ns | |
| Input and Output Timing Reference Level | | 0.9 | V | 1 |

Note: 1. See SRAM AC test output load on page 11.

JTAG AC Characteristics

| Parameter | Symbol | Min | Max | Unit | Note |
|---------------------------|-------------------|-----|-----|------|------|
| TCK Cycle Time | t _{CHCH} | 50 | - | ns | |
| TCK High Pulse Width | t _{CHCL} | 20 | - | ns | |
| TCK Low Pulse Width | t _{CLCH} | 20 | - | ns | |
| TMS Input Setup Time | t _{MVCH} | 5 | - | ns | |
| TMS Input Hold Time | t _{CHMX} | 5 | - | ns | |
| TDI Input Setup Time | t _{DVCH} | 5 | - | ns | |
| TDI Input Hold Time | t _{CHDX} | 5 | - | ns | |
| SRAM Input Setup Time | t _{SVCH} | 5 | - | ns | |
| SRAM Input Hold Time | t _{CHSX} | 5 | - | ns | |
| Clock Low to Output Valid | t _{CLQV} | 0 | 10 | ns | |

JTAG Timing Diagram

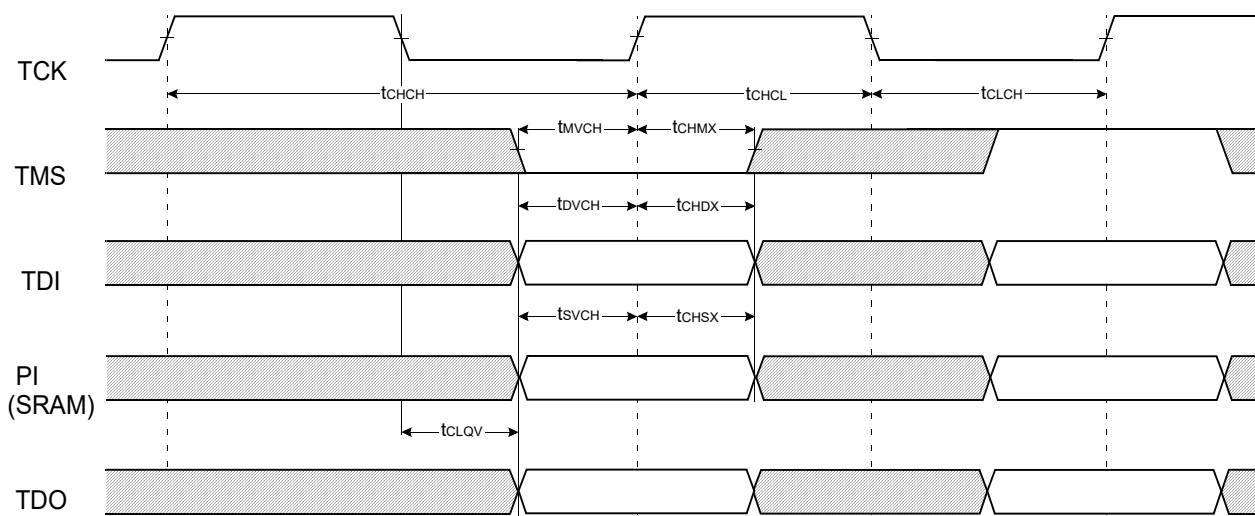

S7T1636U4M
S7T1618U4M
S7T1609U4M 512Kx36 & 1Mx18 & 2Mx9 Quadruple-II+ BL4 SRAM w/ ODT

165 FBGA Package Dimensions - Lead & Lead Free
 13mm x 15mm Body, 1.0mm Bump Pitch, 11x15 Ball Grid Array

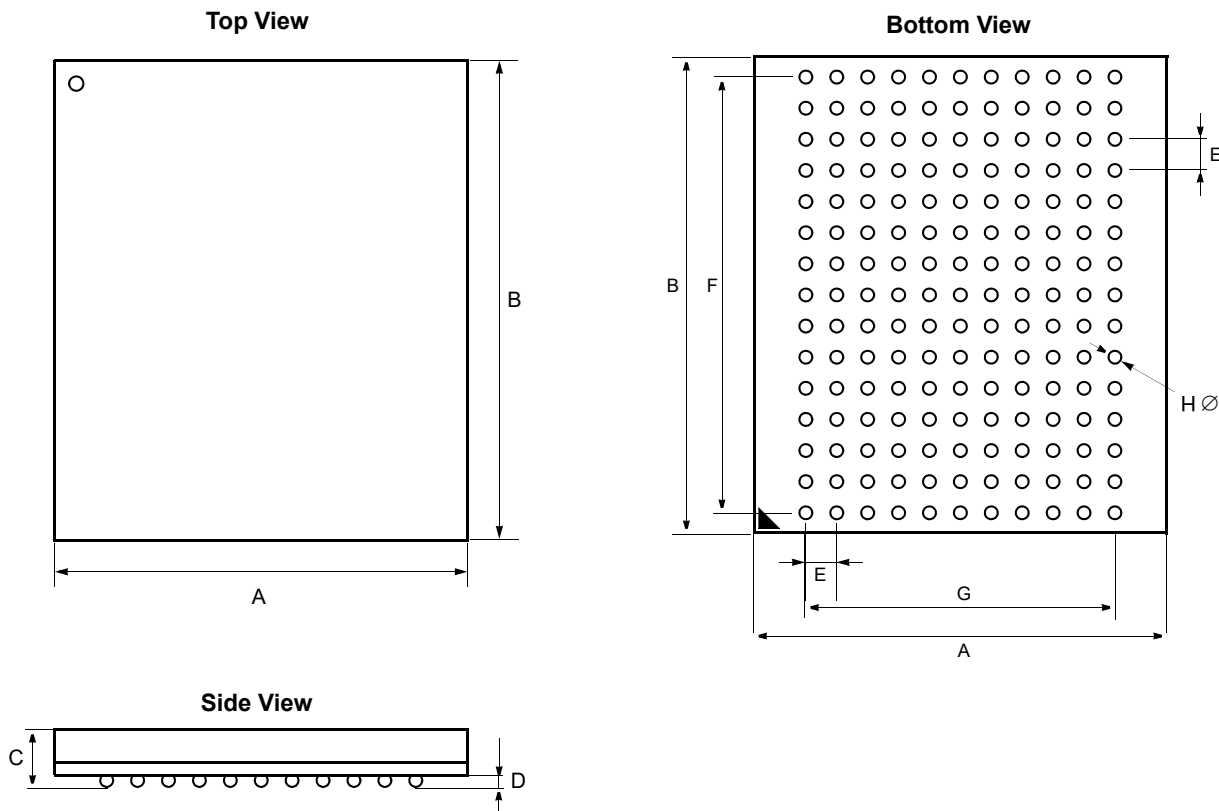

| Symbol | Value | Units | Note | Symbol | Value | Units | Note |
|----------|-------------|-------|------|----------|------------|-------|------|
| A | 13 ± 0.1 | mm | | E | 1.0 | mm | |
| B | 15 ± 0.1 | mm | | F | 14.0 | mm | |
| C | 1.3 ± 0.1 | mm | | G | 10.0 | mm | |
| D | 0.35 ± 0.05 | mm | | H | 0.5 ± 0.05 | mm | |